

# TECHNICAL DATASHEET



## END CAP

03 Update - 01/2025

### TECHNICAL DATA

Article No	001 117 0140 0450
d (mm)	450
le (mm)	200
s (mm)	40,9
Weight (Kg)	17,400
Box Quantity (pcs)	1
Box Dimension (pcs)	48x56x38,5

### INJECTION MOULDED

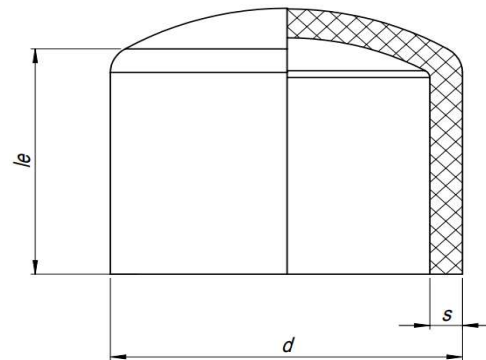

### IDENTIFICATION OF PRODUCT

D(mm)	450
SDR	11
RAW METARIAL	PE 100
PRESSURE CLASS	16 Bar Water 10 Bar Gas
TRADEMARK	NTG
EXECUTION	Injection Moulded
STANDARD	EN 12201-3 EN 1555-3 AS /NZS 4129

### SPECIFICATION

Long Spigot

Tolerance on diameters and thickness according to the standards. The other dimensions are specialized. Tolerance  $\pm 5\%$ . NTG PLASTIK reserves all the right to change any information without giving prior notice. The production, distribution and utilization of this document without explicit authorization is prohibited.

Fr 161 Rev 00